

Crash course – Verification of Finite Automata

Binary Decision Diagrams

Exercise session - 24.11.201

Romain Jacob

Equivalence of representations

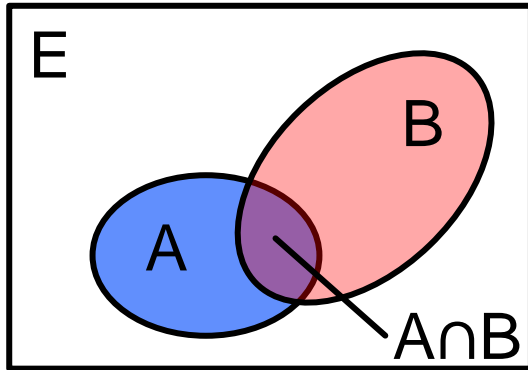

Sets

- Set algebra
- \cup, \cap, \neg

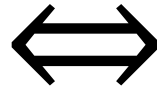

$$\begin{aligned}\psi_E &= 1 \\ \psi_A &= f \\ \psi_B &= g \\ \psi_{A \cap B} &= f \cdot g\end{aligned}$$

Boolean functions/
Characteristic functions

- Boole algebra
- $+, \cdot, \neg$

Equivalence of representations

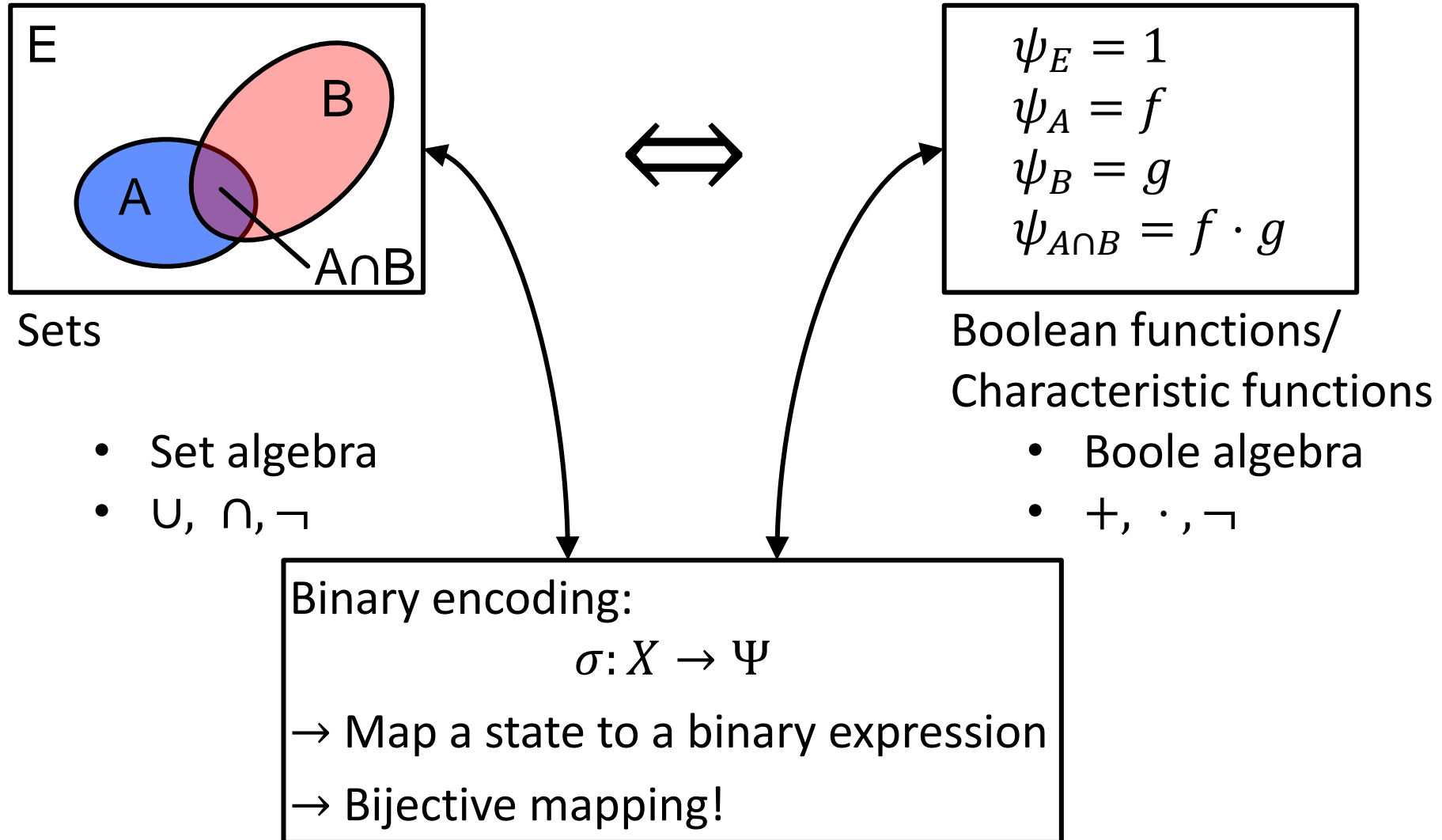

Equivalence of representations

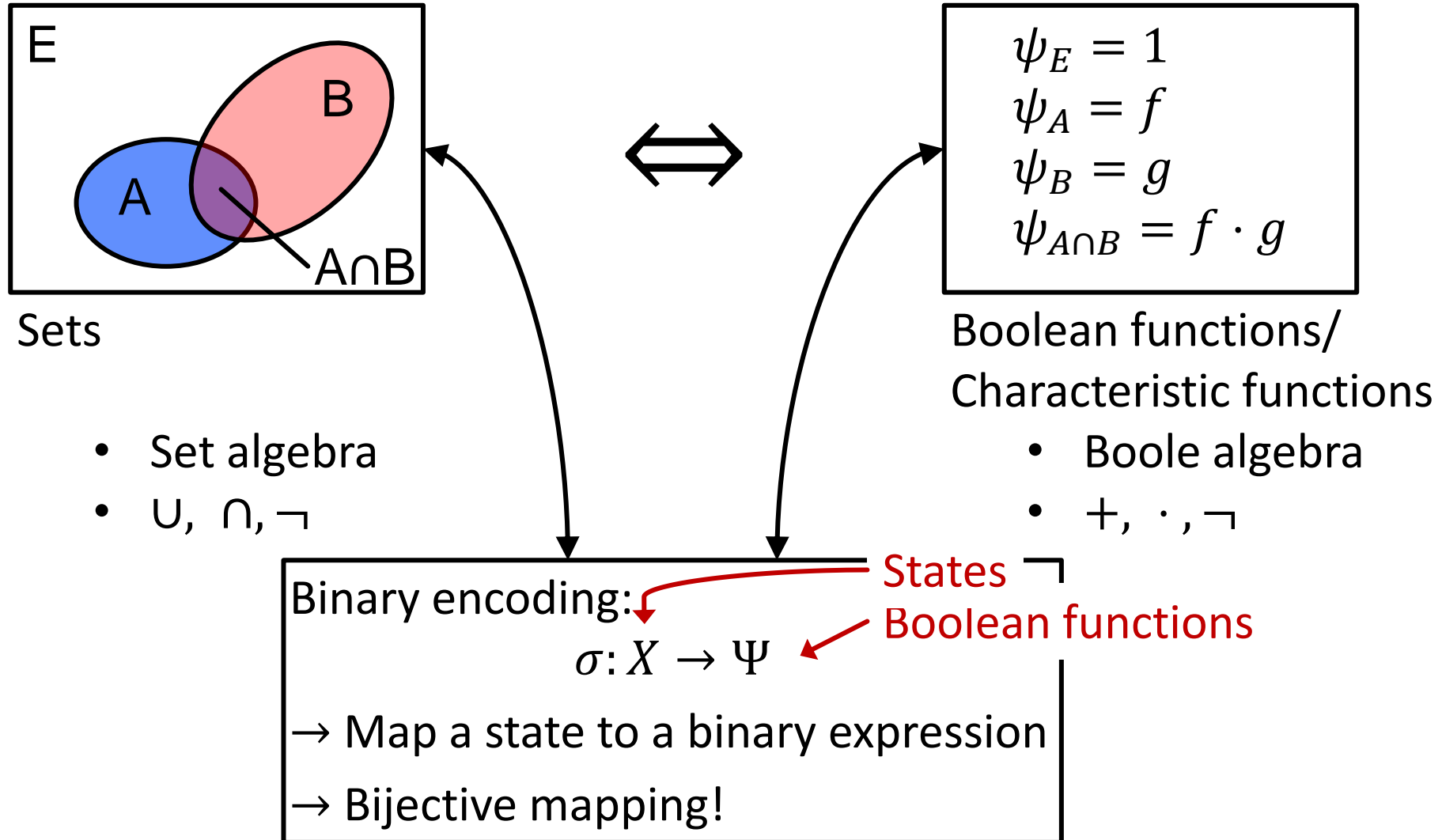

Equivalence of representations

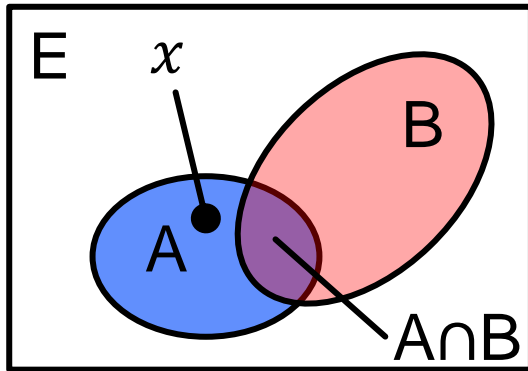

Sets

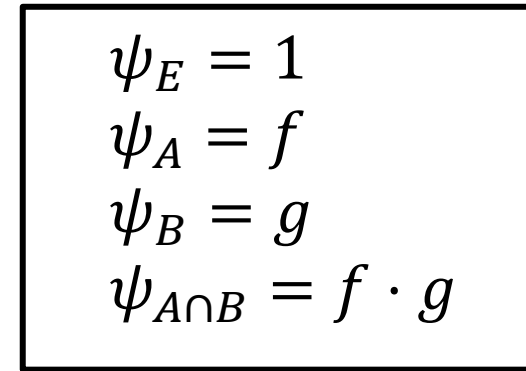

Boolean functions/
Characteristic functions

- A
- $s \in A$

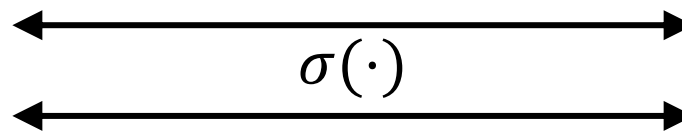

- ψ_A
- $\psi_A(\sigma(s)) = 1$
 $\sigma(s) \models \psi_A$
 or just $s \models \psi_A$

Example:

$$\sigma(s) = x_1 \bar{x}_0 = (1,0) \text{ and } \psi_A = x_1 + x_0$$

$$\rightarrow s \models \psi_A ?$$

↑
Reads “s satisfies ψ_A ”

Binary Decision Diagrams

Based on the Boole-Shannon decomposition:

$$\underline{f} = \bar{x} \cdot \underline{f|_{x=0}} + x \cdot \underline{f|_{x=1}}$$

Boolean function of n and $(n - 1)$ variables

→ For a given order of variable, **the decomposition is unique!**

→ Hence the uniqueness of O(rdered)BDD.

Reminder:

In practice, simplicity of BDD depends strongly on the order.

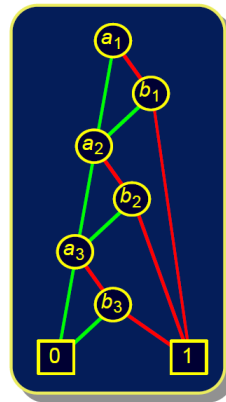

Good

$(a_1 \wedge b_1) \vee$
 $(a_2 \wedge b_2) \vee$
 $(a_3 \wedge b_3)$

vs.

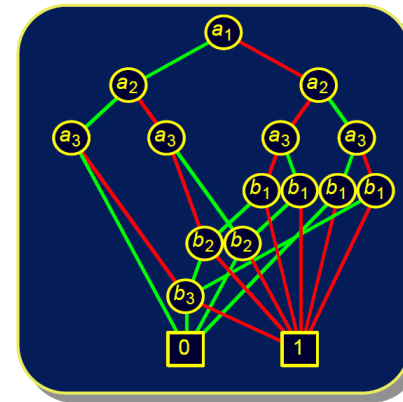

Bad ordering

Binary Decision Diagrams: an example

$$f: x_1 + \overline{x_1} x_2 + \overline{x_2} \overline{x_3}$$

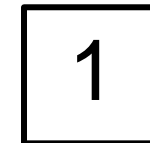
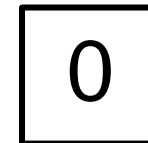
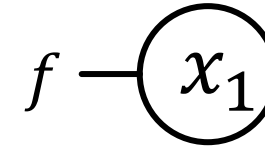

Binary Decision Diagrams: an example

$$f: x_1 + \overline{x_1} x_2 + \overline{x_2} \overline{x_3}$$

Fall $x_1 = 0$

$$f|_{x_1=0}: x_2 + \overline{x_2} \overline{x_3}$$

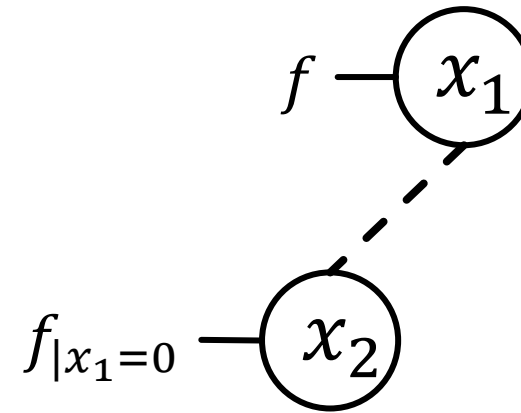

0 ---
1 ———

0

1

Binary Decision Diagrams: an example

$$f: x_1 + \overline{x_1} x_2 + \overline{x_2} \overline{x_3}$$

Fall $x_1 = 0$

$$f_{|x_1=0}: x_2 + \overline{x_2} \overline{x_3}$$

Fall $x_2 = 0$

$$f_{|x_1=0, x_2=0}: \overline{x_3}$$

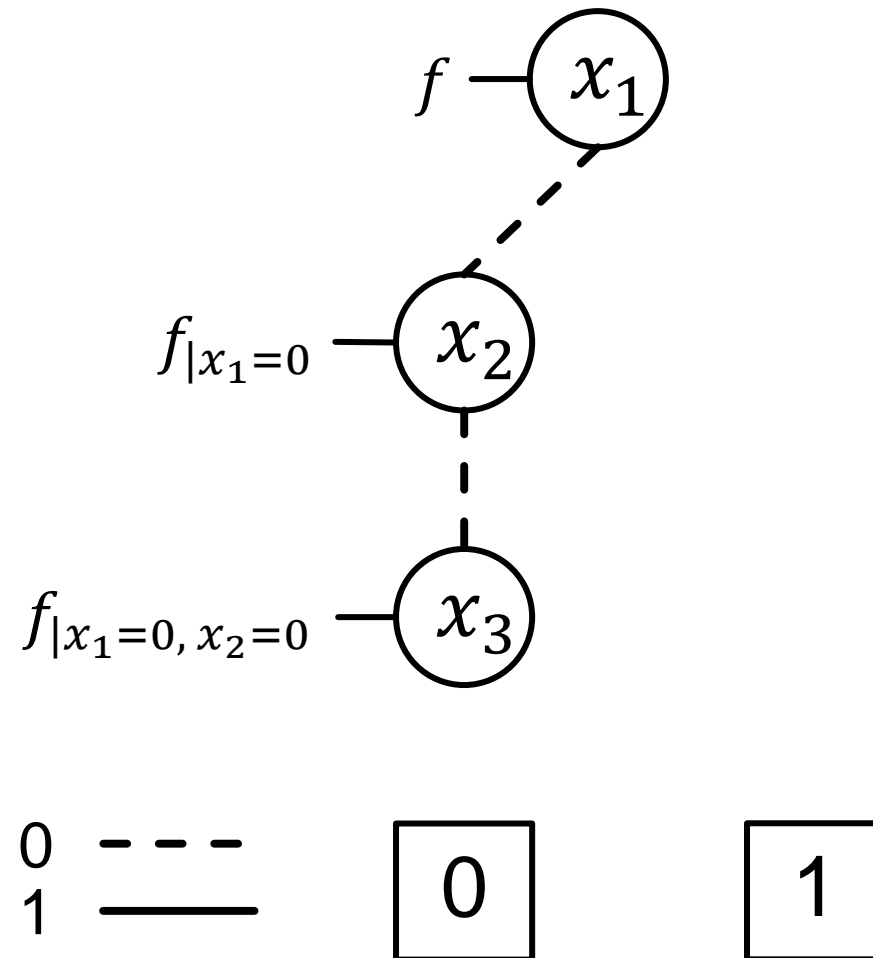

Binary Decision Diagrams: an example

$$f: x_1 + \overline{x_1} x_2 + \overline{x_2} \overline{x_3}$$

Fall $x_1 = 0$

$$f|_{x_1=0}: x_2 + \overline{x_2} \overline{x_3}$$

Fall $x_2 = 0$

$$f|_{x_1=0, x_2=0}: \overline{x_3}$$

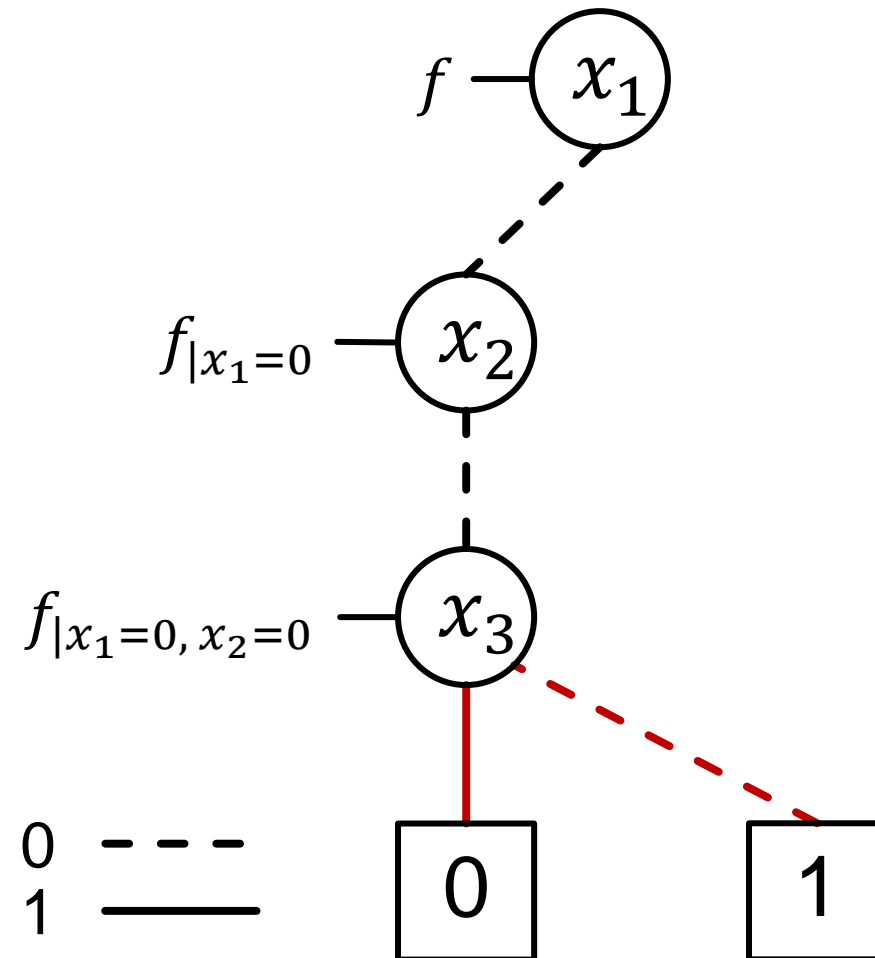

Binary Decision Diagrams: an example

$$f: x_1 + \overline{x_1} x_2 + \overline{x_2} \overline{x_3}$$

Fall $x_1 = 0$

$$f_{|x_1=0}: x_2 + \overline{x_2} \overline{x_3}$$

Fall $x_2 = 0$

$$f_{|x_1=0, x_2=0}: \overline{x_3}$$

Fall $x_2 = 1$

$$f_{|x_1=0, x_2=1}: 1$$

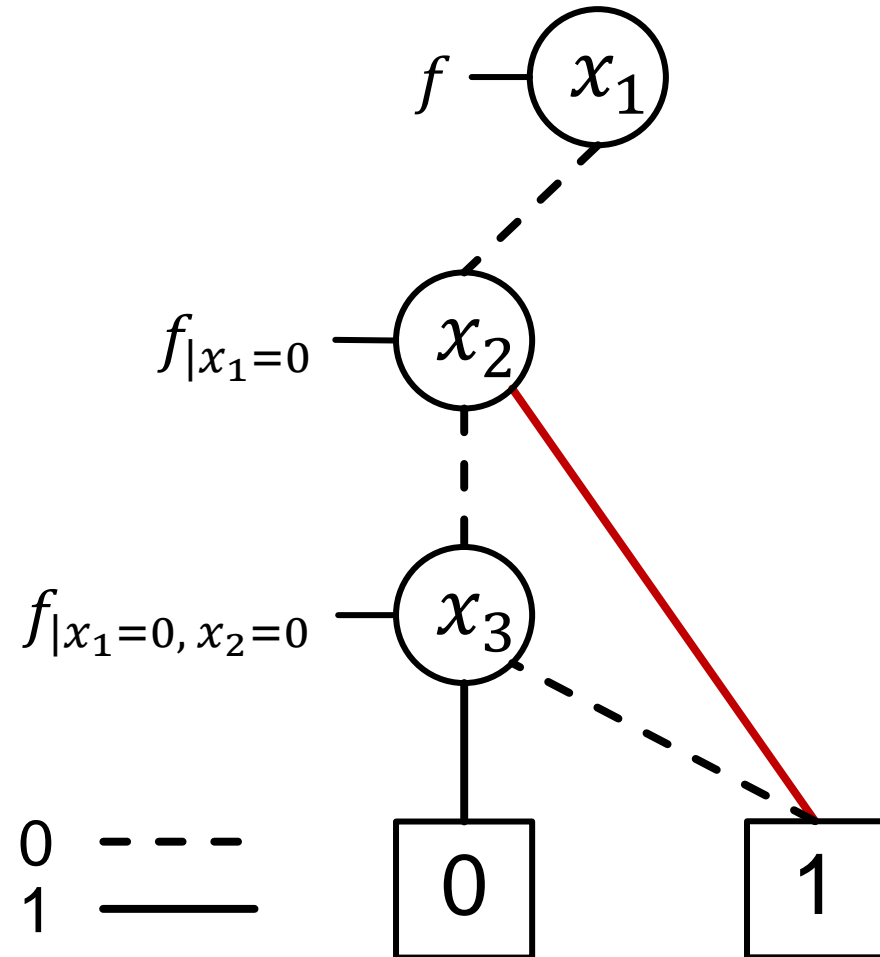

Binary Decision Diagrams: an example

$$f: x_1 + \overline{x_1} x_2 + \overline{x_2} \overline{x_3}$$

Fall $x_1 = 0$

$$f_{|x_1=0}: x_2 + \overline{x_2} \overline{x_3}$$

Fall $x_2 = 0$

$$f_{|x_1=0, x_2=0}: \overline{x_3}$$

Fall $x_2 = 1$

$$f_{|x_1=0, x_2=1}: 1$$

Fall $x_1 = 1$

$$f_{|x_1=1}: 1$$

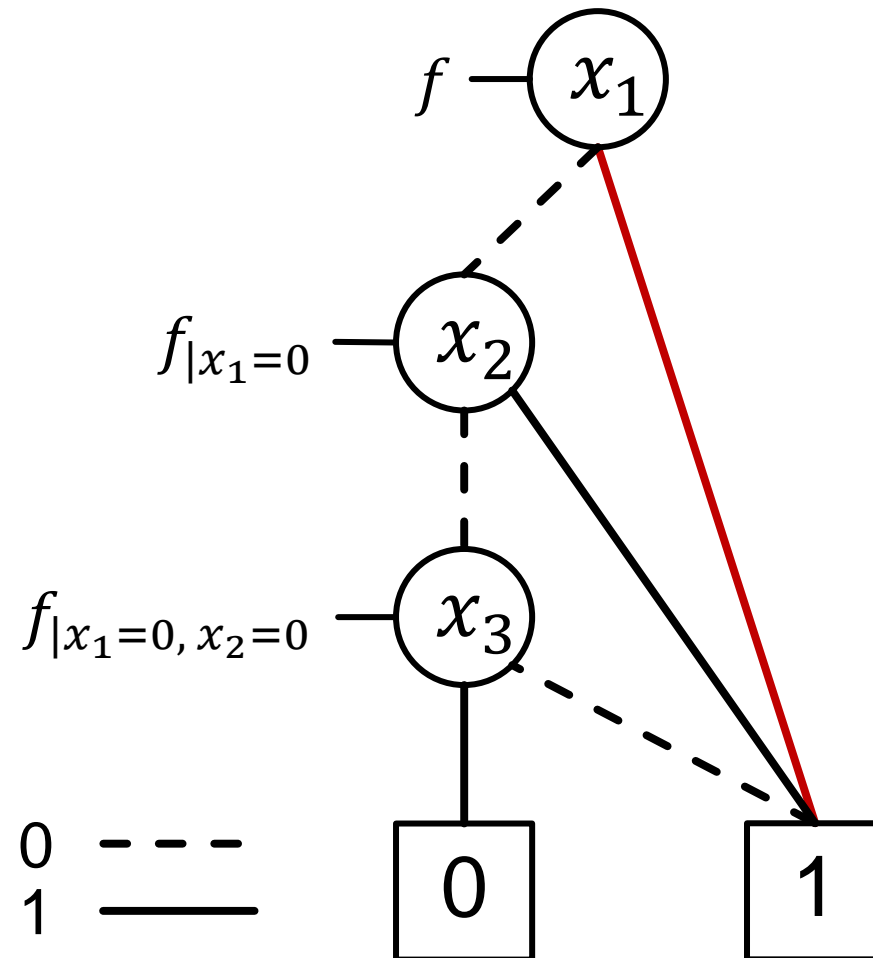

Crash course – Verification of Finite Automata

Binary Decision Diagrams

Your turn !

Slides online on my webpage:

<http://people.ee.ethz.ch/~jacobr/>

Ex1: Sets Representation

“Each state is either a nominal or an error state”.

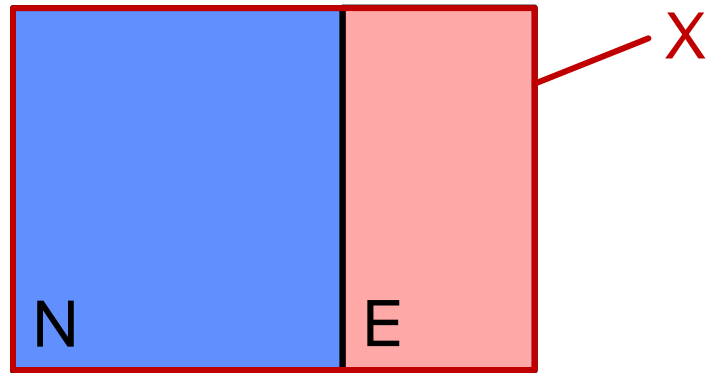

$$\Rightarrow N \cup E = X \Leftrightarrow \psi_N + \psi_E = 1$$

Ex1: Sets Representation

“If a state is in the overflow set, it is not a nominal state”.

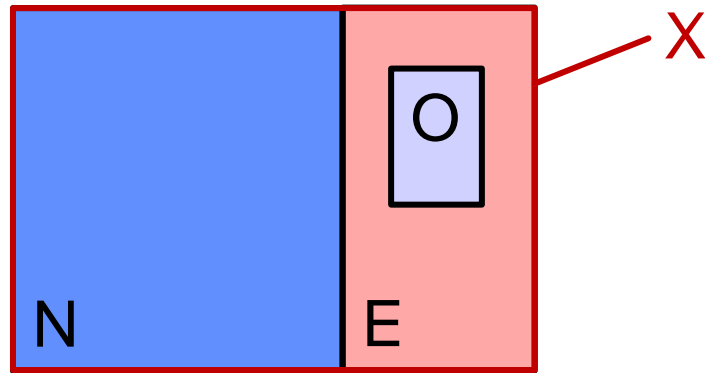

$$\Rightarrow N \cap O = \emptyset \Leftrightarrow \psi_N \cdot \psi_O = 0$$

But note it is not necessarily true !!
Although you would like it to be...

Ex1: Sets Representation

Describe Q_1 , the set of error states which are not an overflow, in term of sets and characteristic functions.

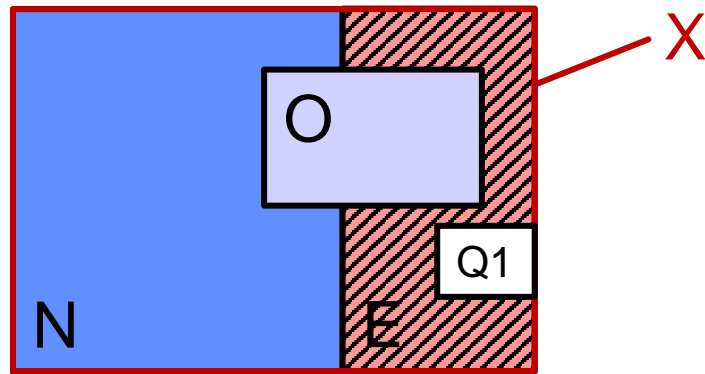

$$\Rightarrow Q_1 = E \setminus O \quad \Leftrightarrow \quad \psi_{Q_1} = \psi_E \cdot \overline{\psi_O}$$

Ex1: Sets Representation

- Describe $Q2$, satisfying " $O \Rightarrow E$ ", i.e., the set of state for which this property holds, in term of sets and characteristic functions.

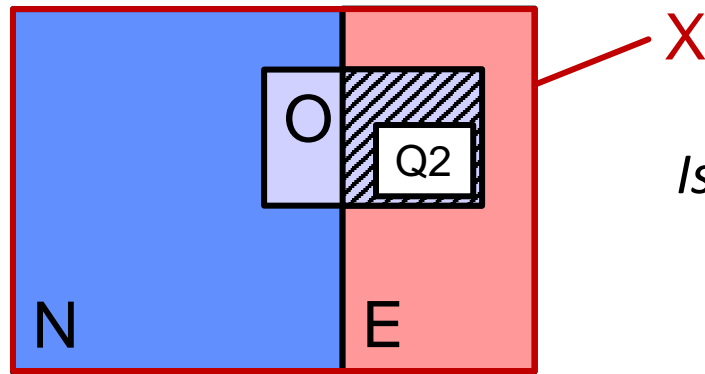

Is that correct ?

Ex1: Sets Representation

- Describe Q2, satisfying " $O \Rightarrow E$ ", i.e., the set of state for which this property holds, in term of sets and characteristic functions.

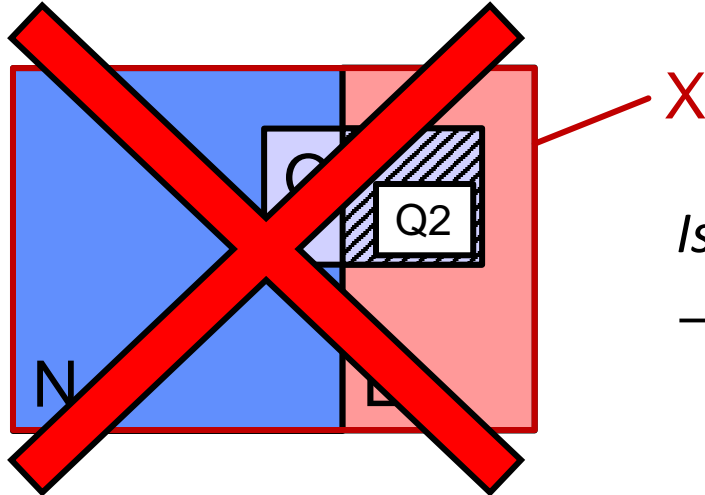

Is that correct? No!

→ *What if a state is not in O?
Property is always true!*

Ex1: Sets Representation

- Describe Q_2 , satisfying " $O \Rightarrow E$ ", i.e., the set of state for which this property holds, in term of sets and characteristic functions.

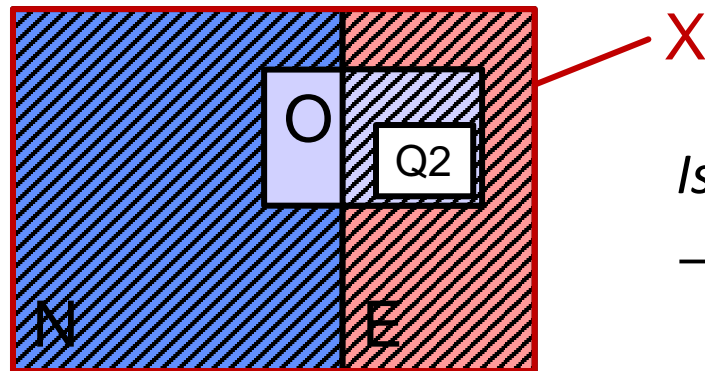

Is that correct? No!

→ *What if a state is not in O?*

Property is always true!

$$\Rightarrow \quad Q_2 = (O \cap E) \cup \bar{O} = (O \cup \bar{O}) \cap (E \cup \bar{O}) \\ = X \cap (E \cup \bar{O}) \\ = E \cup \bar{O} \quad \Leftrightarrow \quad \psi_{Q_2} = \psi_E + \bar{\psi}_O$$

Ex2.1 Verification using BDDs

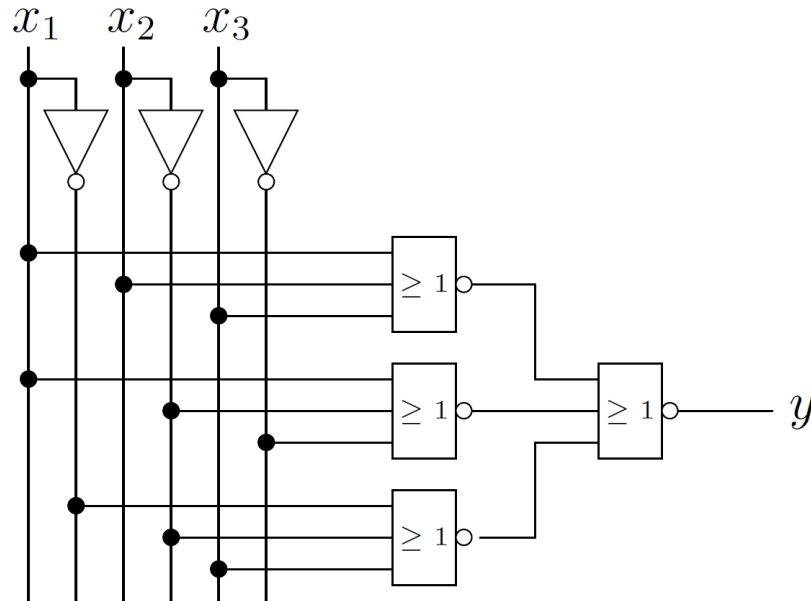

$$\text{a) } f_2 : y = \overline{\overline{x_1 + x_2 + x_3 + \overline{x_1 + \overline{x_2} + \overline{x_3}} + \overline{\overline{x_1} + \overline{x_2} + x_3}}}$$

Ex2.1 Verication using BDDs

$$f_1 : (x_1\overline{x_2} + x_1x_3 + \overline{x_2}x_3 + \overline{x_1}x_2\overline{x_3})$$

Fall $x_1 = 0$

$$y|_{x_1=0} = \overline{x_2}x_3 + x_2\overline{x_3}$$

Fall $x_2 = 0$

$$y|_{x_1=0, x_2=0} = x_3$$

Fall $x_2 = 1$

$$y|_{x_1=0, x_2=1} = \overline{x_3}$$

Fall $x_1 = 1$

$$y|_{x_1=1} = \overline{x_2} + x_3 + \overline{x_2}x_3$$

Fall $x_2 = 0$

$$y|_{x_1=1, x_2=0} = 1$$

Fall $x_2 = 1$

$$y|_{x_1=1, x_2=1} = x_3$$

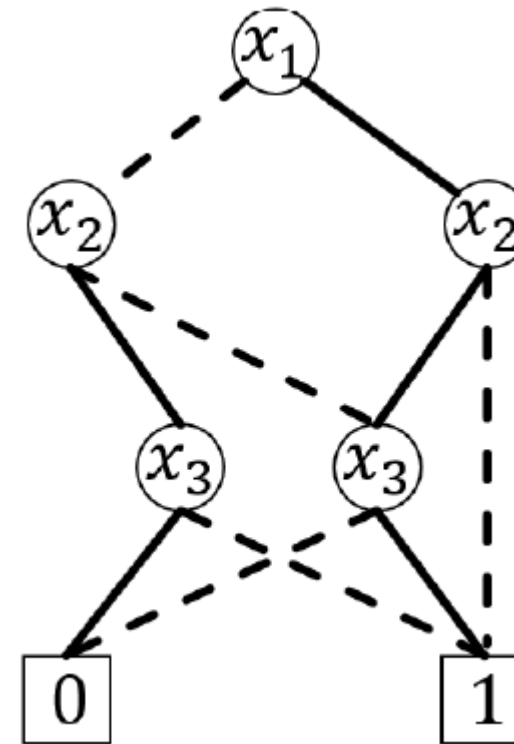

Ex2.1 Verification using BDDs

$$f_2 : y = \overline{\overline{x_1 + x_2 + x_3} + \overline{x_1 + \overline{x_2} + \overline{x_3}} + \overline{x_1 + \overline{x_2} + x_3}}$$

Fall $x_1 = 0$

$$y|_{x_1=0} = \overline{\overline{x_2 + x_3} + \overline{\overline{x_2} + \overline{x_3}}}$$

Fall $x_2 = 0$

$$y|_{x_1=0, x_2=0} = \overline{\overline{x_3} + \overline{1 + \overline{x_3}}} = x_3$$

Fall $x_2 = 1$

$$y|_{x_1=0, x_2=1} = \overline{1 + \overline{\overline{x_3}}} = \overline{x_3}$$

Fall $x_1 = 1$

$$y|_{x_1=1} = \overline{\overline{1 + 1 + \overline{\overline{x_2} + x_3}}} = \overline{x_2} + x_3$$

Fall $x_2 = 0$

$$y|_{x_1=1, x_2=0} = 1$$

Fall $x_2 = 1$

$$y|_{x_1=1, x_2=1} = x_3$$

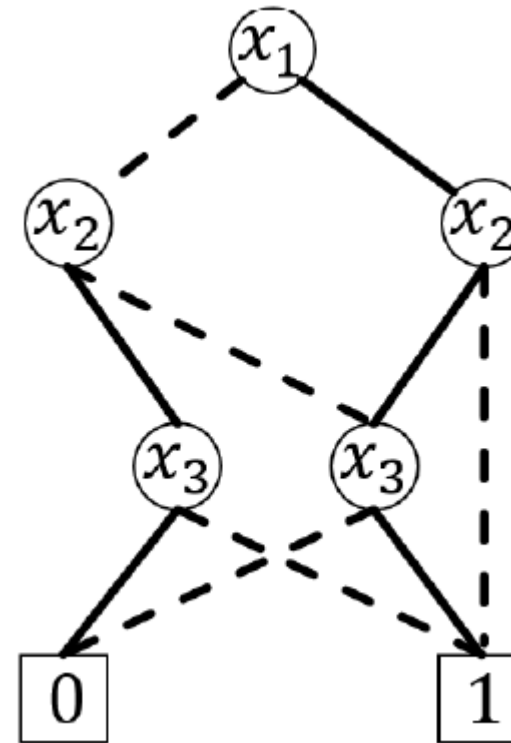

Ex2.2 BDDs with respect to different orderings

$$g(x_1, x_2, y_1, y_2) = (x_1 \equiv y_1) \cdot (x_2 \equiv y_2), \quad \Pi : x_1 < x_2 < y_1 < y_2$$

$$\begin{aligned} \text{a) } g = & x_1 \{ x_2 [y_1 (y_2) + \overline{y_1} (0)] + \overline{x_2} [y_1 (\overline{y_2}) + \overline{y_1} (0)] \} \\ & + \overline{x_1} \{ x_2 [y_1 (0) + \overline{y_1} (y_2)] + \overline{x_2} [y_1 (0) + \overline{y_1} (\overline{y_2})] \} \end{aligned}$$

b)

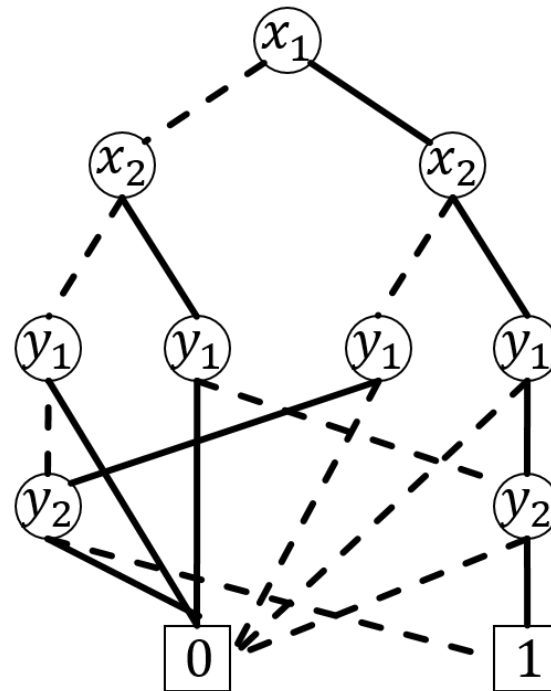

Ex2.2 BDDs with respect to different orderings

$$g(x_1, x_2, y_1, y_2) = (x_1 \equiv y_1) \cdot (x_2 \equiv y_2) , \quad \Pi' : x_1 < y_1 < x_2 < y_2$$

$$\begin{aligned} \text{c) } g = & x_1 \{ y_1 [x_2 (y_2) + \overline{x_2} (\overline{y_2})] + \overline{y_1} [0] \} \\ & + \overline{x_1} \{ y_1 [0] + \overline{y_1} [x_2 (y_2) + \overline{x_2} (\overline{y_2})] \} \end{aligned}$$

Better ordering:
6 vs. 9 nodes

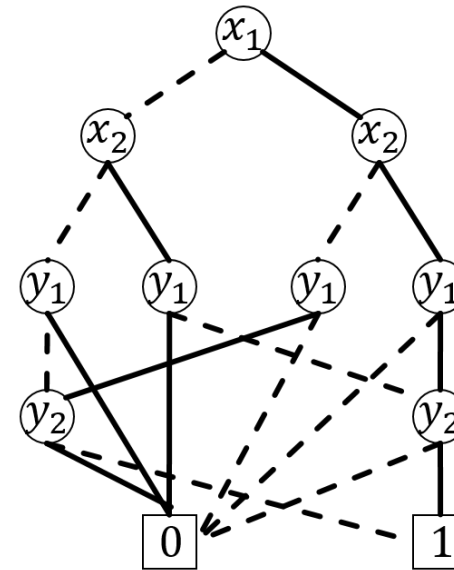
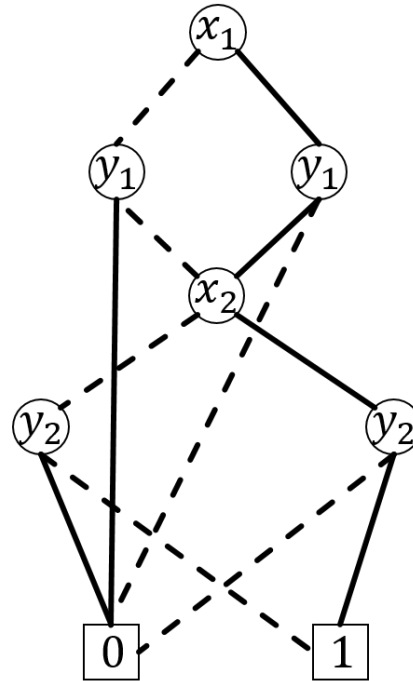

About the lecture exercise feedback

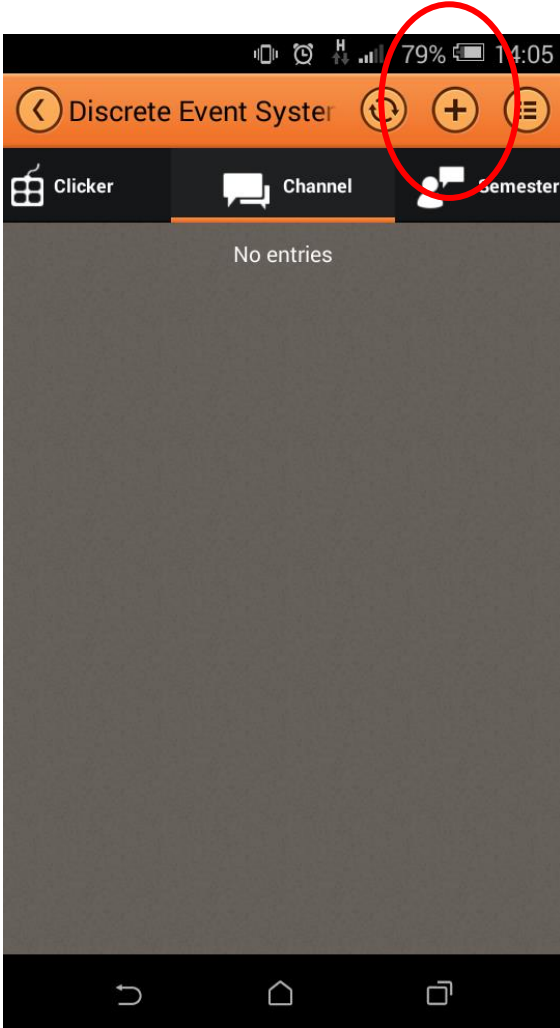
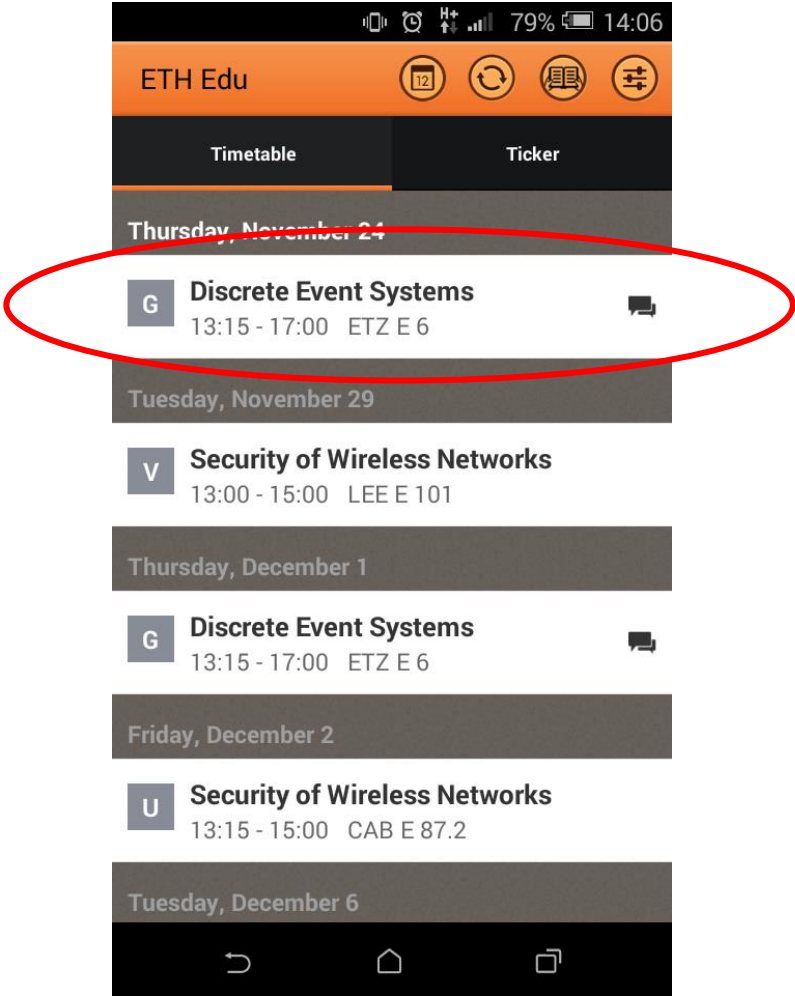

Crash course – Verification of Finite Automata

Binary Decision Diagrams

Slides online on my webpage:

<http://people.ee.ethz.ch/~jacobr/>

See you next week!